

NEXT NGA WEST (N2W) PROGRAM

ACQUISITION INFORMATION BRIEF

Prepared by Kansas City District
Industry Information Forum
August 2017

“The views, opinions and findings contained in this report are those of the author(s) and should not be construed as an official Department of the Army position, policy or decision, unless so designated by other official documentation.”



**US Army Corps
of Engineers.**



INTRODUCTION

Presented by:

Stephanie Hall Program Manager



US Army Corps
of Engineers.



PURPOSE

- Provide updated information about the N2W program to interested firms and individuals
- Assist interested firms in understanding the requirements, planning for success, and identifying available resources
- Explain the Two-Phase Design-Build delivery method
- Facilitate sub-contracting opportunities with prime contractors

AGENDA

- Overview of N2W
- N2W Specific Contracting Notes
- Construction Acquisition Update
- Small Business Opportunities
- Sub-Contracting Opportunities with Interested Prime Contractors



US Army Corps
of Engineers.



OVERVIEW OF N2W



US Army Corps
of Engineers.



WHO IS THE NGA AND WHAT IS N2W?

- The National Geospatial-Intelligence Agency (NGA) delivers products that provide decisive advantage to
 - warfighters
 - policymakers
 - intelligence professionals
 - first responders
- N2W will be NGA's new state-of-the-art facility in North St. Louis. It will position NGA to better meet future mission requirements through a more robust information technology infrastructure and collaborative workspace.



US Army Corps
of Engineers.

6



SITE LOCATION



US Army Corps
of Engineers.



DESIGN AND CONSTRUCTION PROGRAM INFORMATION

- At this time, the project is expected to be funded in phases
 - FY16 - Site Selection
 - FY17 - Real Estate Acquisition
 - FY18-19 - MILCON Construction
 - FY23+ - Outfitting and Transition Phase
- NGA desires a “turn-key” construction contract to include Furniture Fixtures & Equipment and Transition to full operations phase services



US Army Corps
of Engineers.

8



N2W FACILITY REQUIREMENTS

Main Operations Building	712,000 SF
Central Utility Plant	38,000 SF
Visitor Control Center	7,300 SF
Parking Garages	992,000 SF
Remote Inspection Facility*	9,500 SF
Surface Parking*	175,000 SF
2 Access Control Points*	
Site Improvements: Roads, perimeter security, utilities, etc.	
Landscaping*	
Temporary Integrated Project Office*	

* To be set aside for Small Business Contract Opportunity

N2W SPECIFIC CONTRACTING NOTES



US Army Corps
of Engineers.



CONTRACTING NOTES

This is a federal contract that follows Federal Acquisition Requirements, Department of Defense, Army, Corps of Engineers and NGA rules and regulations, and has different requirements than state and private commercial contracts.

The US Army Corps of Engineers (USACE) is competing and awarding a Design-Build (D-B) Construction Contract, and up to 5 separate Small Business Construction Contracts.



US Army Corps
of Engineers.



CONTRACTUAL RELATIONSHIPS

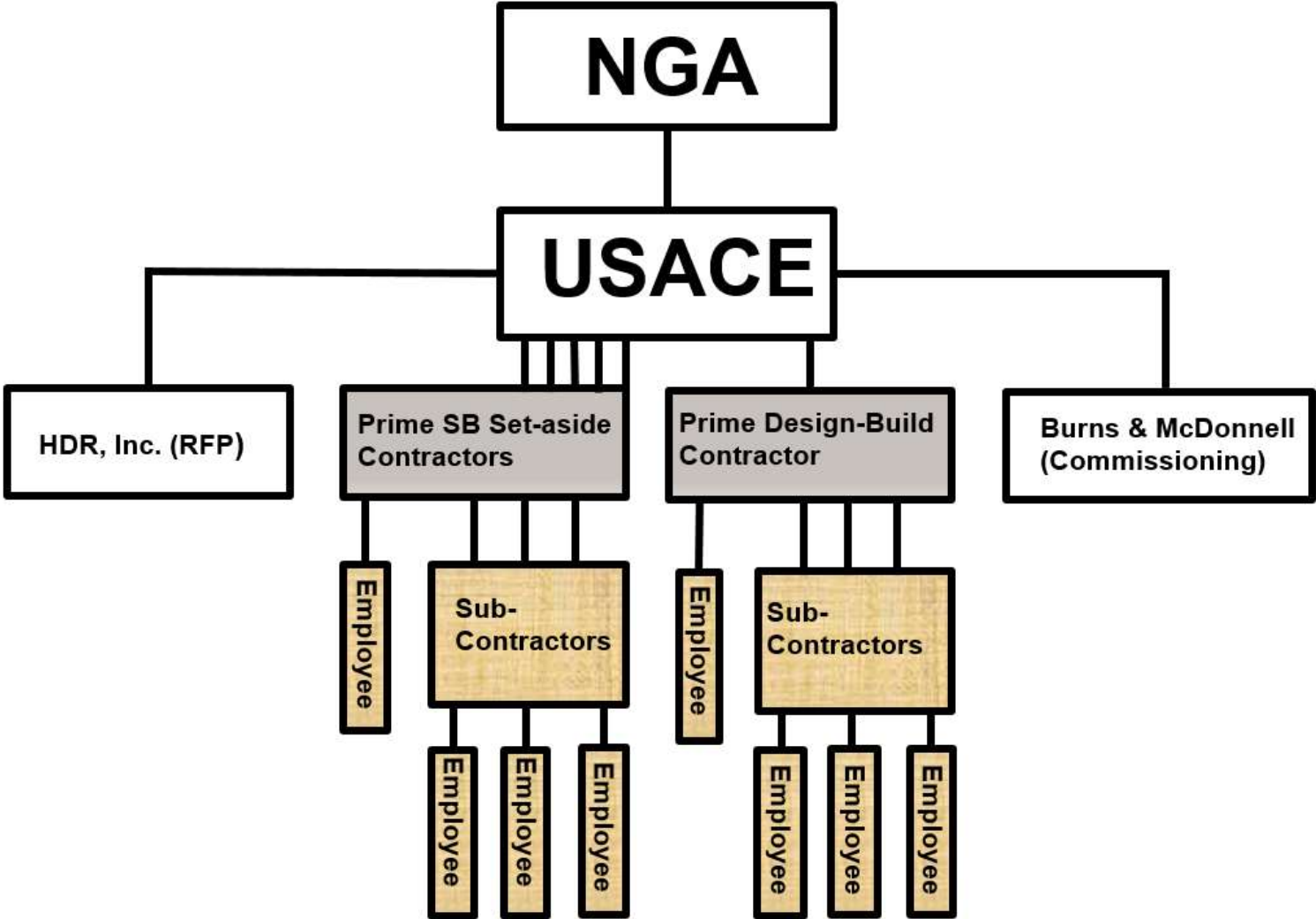

SECURE CONSTRUCTION REQUIREMENTS

Secure construction for intelligence facilities requires:

- All personnel working on site subject to local and/or national agency background checks
- Fence and construction access control points in place at start of work
- All workers issued badges that enable ID and electronic checking in and out of the site
- Computer, phone and camera use on site limited to approved individuals and devices
- Security clearances or escorts for workers entering facilities after completion



US Army Corps
of Engineers.



EQUAL EMPLOYMENT OPPORTUNITY

- DOL Affirmative Action Goals for St. Louis
 - Women 6.9% Participation by trade
 - Minorities 14.7% Participation by trade
- Department of Labor's Office of Federal Contract Compliance Programs (OFCCP) has selected N2W under their mega project program
- OFCCP will engage to help firms implement these goals and others for veterans and individuals with disabilities



US Army Corps
of Engineers.



CONSTRUCTION ACQUISITION UPDATE



US Army Corps
of Engineers.



N2W CONSTRUCTION ACQUISITION

The following information is current at this time however:

- The dates listed in this presentation are TARGET dates and several factors (many outside our control may influence the final dates).
- This is a high level look at the program and definition is ongoing, so things may CHANGE.



US Army Corps
of Engineers.



N2W CONSTRUCTION ACQUISITION

- Award one Design-Build Contract to Construct the main operations building and integrated facilities using Two-Phase Design-Build Selection Procedures.
- Procure small business set aside projects using Design-Bid-Build delivery method after the acquisition of the D-B Contract.



US Army Corps
of Engineers.



2 PHASE DESIGN-BUILD PROCEDURES

Phase 1: Qualifications based selection of maximum 3 offerors:

- Clark-JE Dunn N2W, a Joint Venture
- McCarthy HITT – Next NGA West JV
- Mortenson-Alberici, a Joint Venture

The selected firms will be invited to submit technical proposals in Phase 2



US Army Corps
of Engineers.



2 PHASE DESIGN-BUILD PROCEDURES

Phase 2 competition among the selected firms anticipated to include the following:

- Requires submission of technical and price proposals
- Design work to demonstrate technical solutions to RFP performance requirements
- Small business participation plan is an evaluation factor
- 90-120 days total period for Phase 2 proposal preparation



US Army Corps
of Engineers.



N2W CONSTRUCTION ACQUISITION

- D-B RFP focused on narrative performance based requirements except where agency criteria dictate prescriptive items
- Design-Builder to perform transition phase O&M services from beneficial occupancy through full operational capability (options estimated at 12-24 months)
- During construction the site will be shared with contractors working on set-aside projects and follow on IT & Security contractors

N2W CONSTRUCTION ACQUISITION

- Draft Phase 1 RFP posted November 2016 for comments
- Phase 1 RFP posted March 31, 2017
- Phase 1 Proposals received May 2, 2017
- Announcement of Phase 1 offerors invited to Phase 2 September 6, 2017
- Target: issue Phase 2 RFP in January 2018
- Target: D-B contract award September 2018

CONSTRUCTION ACQUISITION TIMELINE



SMALL BUSINESS OPPORTUNITIES



US Army Corps
of Engineers.



SMALL BUSINESS OPPORTUNITIES

- Set-aside prime construction contracts for:
 - Government's Integrated Program Office on site
 - Remote Inspection Facility
 - Surface Parking Lot
 - Access Control Points
 - Landscaping
- Set-asides for follow on A-E CMS Contracts
- Subcontracts on the main operational facilities.
- SAM registration is key for prime contractors

Reminder - The City of St. Louis is responsible for the site preparation work which is underway now.

SMALL BUSINESS OPPORTUNITIES

Subcontracts: new percentages updated in the future, current below

Program	Subcontracting Goals
Small Business	40%
Small Disadvantaged Business	3%
Woman Owned Small Business	7%
HUB Zone	1%
Service Disabled Veteran Owned SB	3%
Veteran Owned Small Business	2%



US Army Corps
of Engineers.



SUGGESTED STEPS FOR SUBCONTRACTORS

- Reach out now to the down-selected firms
- Assess your workforce & capabilities
- Watch for subcontractor / small business outreach events from offerors
- Visit www.nextngawest.com for program updates

REQUIREMENTS TO BE A PRIME CONTRACTOR

System for Award Management - www.SAM.gov

- Free registration required to contract with the Federal Government
- Gathers basic information to ensure eligibility for award

D-U-N-S Number - www.dnb.com/get-a-duns-number.html

- A Unique identification number for businesses.
- Recommend vendors register with Dun & Bradstreet for a DUNS BEFORE starting the SAM.gov registration process.

NAICS code www.census.gov/eos/www/naics/index.html

- North American Industry Classification System
- The type of work your company primarily performs.
- Search the website by key word to find your industry NAICS code.



US Army Corps
of Engineers.



SMALL BUSINESS RESOURCES

Association of Procurement Technical Assistance Center (APTAC) <http://www.aptac-us.org/>

- Assist small businesses with sam.gov registration and other aspects of federal contracting
- Typically done for little-to-no cost

<p>MO PTAC University of Missouri Columbia W1018 Lafferre Hall Columbia, MO 65211</p> <p>Jana Weitkemper Procurement Specialist (573) 882-9398 Email Address: weitkemperj@missouri.edu</p>	<p>MO PTAC St. Louis http://www.moptac.net 10650 Gateway Blvd, St. Louis, MO 63132 (314) 400-7378</p> <p>Millie Miller-Hoover Procurement Counselor Phone: (314) 400-7378 Email Address: millerhooverm@missouri.edu</p>	<p>IL PTAC @ John A. Logan College 700 Logan College Rd. Carterville, IL 62981 (618)-985-2828 x8571</p> <p>Theresa Ebeler PTAC Advisor Phone: (618)-420-8313</p> <p>Email Address: centralptac@gmail.com</p>	<p>IL PTAC @ Western Illinois University 301 Oak Street Room 2-27 Quincy, IL 62301 (217) 223-5636</p> <p>Mary Turner, CCAS Center Director Phone: (217) 223-5636</p> <p>Email Address: mr-turner@wiu.edu</p>
---	--	--	---



WHERE TO FIND CONTRACTING OPPORTUNITIES

FBO.gov - Federal Business Opportunities Website

- All Solicitations, Invitations For Bids etc., are posted here.
- Search by Keyword “W912DQ” at FBO.gov, to find any and all solicitations from KC District.

Kansas City District Contracting Office Website

<http://www.nwk.usace.army.mil/BusinessWithUs/Contracting.aspx>

816-389-3812-Main Contracting Division Phone Line

Kansas City District Small Business Deputy

Arthur Saulsberry – Arthur.E.Saulsberry@usace.army.mil



US Army Corps
of Engineers.



THANK YOU FOR PARTICIPATING TODAY



US Army Corps
of Engineers.

