



THE APPRENTICE SCHOOL STUDENT SECTION OF  
THE SOCIETY OF NAVAL ARCHITECTS AND MARINE ENGINEERS



## 2012 Competition Guidelines

Published: October 19, 2011



**Newport News Shipbuilding**  
A Division of Huntington Ingalls Industries



## TABLE OF CONTENTS

Competition Overview.....	3
Phase I. Registration Process.....	4
Phase II. Design Process.....	5
Design Parameters.....	5
Design History Notebook.....	5
Drawings.....	5
Calculations.....	5
Deliverables.....	6
Design Judging Process.....	6
Finalist Announcement.....	7
Phase III. Construction, Testing, and Competition.....	8
Construction.....	8
Boat Trials and Competition.....	8
Awards Ceremony.....	8
Appendix A: Communication.....	9
Purpose.....	9
Responsibilities.....	9
Appendix B: List of Materials.....	10
Construction Material.....	10
Payload.....	10
Propulsion.....	12
Steering.....	14
Appendix C: Drafting Guidelines.....	16
Appendix D: Design Process and Calculation Approach.....	21
Purpose.....	21
Design Spiral.....	21
Developing a Concept Model.....	23
Weight Calculation.....	24
Hydrostatics.....	25
Calculating Displacement.....	27
Calculating Hydrostatic Centers.....	28
Moments of Inertia.....	28
Stability and Trim Calculations.....	29
Speed.....	30
Maneuverability.....	31
Appendix E: Design Phase Judging Criteria.....	32
Appendix F: Test Phase Judging Criteria.....	33
Competition Day.....	34
Glossary.....	36



## 2012 BOAT DESIGN COMPETITION COMPETITION GUIDELINES

### COMPETITION OVERVIEW

The Newport News Shipbuilding Apprentice School [Student Section](#) of The Society of Naval Architects and Marine Engineers ([SNAME](#)) is sponsoring a boat design competition for high school students to increase awareness of the naval architecture profession and the shipbuilding industry. The competition will engage students' math, science, and creative abilities and introduce them to engineering, drafting, project planning, and leadership principles.

Participating high schools will form one or more student teams to work independently to design the fastest and most maneuverable boat, using materials provided, that can carry up to 100 lbs of payload. The designs will be critiqued by a panel of judges (experienced members of the maritime industry), who will examine them for proper drafting practices, ease of production, calculation accuracy, and creativity.

Four designs will be selected for construction by Newport News Shipbuilding Apprentice School students. A head-to-head competition between the four constructed boats will take place at The Mariners' Museum in Newport News, Virginia on Lake Maury. A winner will be selected by a panel of judges evaluating the boat's hydrostatic characteristics, speed, and maneuverability.

### *Key Dates*

#### Phase I. Registration Process

Form a team and register.

**Registration Opens October 17, 2011**  
**Last Day to Register: November 7, 2011**

#### Phase II. Design Process

Teams design their vessel in accordance with Competition Guidelines.

**Final Design Due: December 19, 2011**

#### Phase III. Construction, Testing and Competition

Final four designs will be constructed, tested, and a winner will be selected based on vessel's overall performance and the accuracy of the engineering calculations.

**Final Testing: April 28, 2012**  
**Rain Date: April 29, 2012**



THE APPRENTICE SCHOOL STUDENT SECTION OF  
THE SOCIETY OF NAVAL ARCHITECTS AND MARINE ENGINEERS



## **PHASE I. REGISTRATION PROCESS**

### **Form a Team**

The first step in participating in the Boat Design Competition is forming a winning team. This can be done as a special class project, extra class assignment, or as an after school program.

Teams are limited to a maximum of 6 members. The students are asked to pick a peer Team Captain. There is no limit to the number of teams per school. Teams are best formed from a group of students with a variety of abilities and interests. A team that consists entirely of students with interest in computer aided design (CAD) will not perform as well as a team comprised of students with interests in math, design, science, journalism, etc. We recommend that you talk to the various clubs and associations in your school to try to get a good mix of students on each of your teams (e.g. Math Club, Science Club, journalism or yearbook, design classes or clubs, etc.). Think about the various functions that are required as defined by these guidelines and try to find team members with strengths in each of these areas.

### **Register**

***Due: November 7, 2011***

Instructions for filling out and submitting your registration is provided at:

[www.sname.org/sname/designcompetition](http://www.sname.org/sname/designcompetition).

### **Communication**

All questions and other communications should be handled in accordance with **Appendix A**.

### **Orientation**

***Date: November 7, 2011***

An orientation video will be posted to the website on November 7, 2011 to give the Team Sponsor and Peer Team Captain an overview of the competition and guidelines package, followed by a live Q&A session to take place during the same week. The exact time and date of the Q&A session is TBD and will be announced via the website at a later time. Orientation related information and updates can be located at: [www.sname.org/sname/designcompetition](http://www.sname.org/sname/designcompetition).

### **Withdrawal**

If a design team decides to withdraw from the competition, please notify the Competition Liaison at the e-mail address provided at registration: [www.sname.org/sname/designcompetition](http://www.sname.org/sname/designcompetition).



## **PHASE II. DESIGN PROCESS**

### **Design Parameters**

The following parameters must be met to avoid point deductions or disqualifications:

- Boats must be designed to be easily produced. No single plate can be curved in two planes.
- Any hull shape is acceptable as long as it can be produced with the materials provided and it does not violate the design parameters.
- Boats must be designed with an open hull form.
- Enclosed hull forms will be disqualified.
- Boats must be designed to be constructed using only the materials provided. **See Appendix B**
- Boats must be able to accommodate and secure the steering system, payload, and removable propulsion equipment provided. **See Appendix B.**
- Boats must be able to carry the arranged payload and remain within the specified parameters. **See Appendix B**
- Boats must have a minimum of **6 inches** of freeboard with the payload onboard.

### **Design History Notebook**

The design history notebook is an informal journal that contains the highlights of each team meeting, concepts explored, difficulties encountered during the design process, and the rationale that led to the final design. Be creative; make the design notebook reflect your team's spirit.

### **Drawings**

Designs should be developed using standard computer-aided drafting (CAD) software. Manual drafting is acceptable but must be professionally presented. Teams are required to develop all the necessary views and details needed for design and construction. Required drawings include design drawings, manufacturing drawing(s), nesting plan, paint drawing, and a loading diagram. See **Appendix C** for more details and an example drawing of all necessary views, details and dimensioning. Examples of student drawing submittals can be found at [www.sname.org/designcompetition/designtools/](http://www.sname.org/designcompetition/designtools/).

### **Calculations**

The package shall include the following calculations: weight and centers, hydrostatics, rudder, and static stability. Guidance is also provided for maximizing speed and assessing maneuverability, but these calculations will not be judged. All calculations should be neat and well annotated with clear references to curves. Each calculation should be completed in accordance with the procedure outlined in **Appendix D**. A spreadsheet can be downloaded from [www.sname.org/designcompetition/designtools/](http://www.sname.org/designcompetition/designtools/) for students' use in performing these calculations.



## **Deliverables**

### **Final Design Package**

***Due: December 19, 2011***

Each team is required to submit a Final Design Package that includes, but is not limited to, the following:

- Team's Design History Notebook
- Final drawings set that includes:
  - Design drawings – 3 views and an isometric view
  - Manufacturing drawings
  - Nesting plan
  - Paint drawing
  - Loading diagrams
- A completed calculations spreadsheet
- If a 3D model is used to generate the design, it needs to be included in the package. It is not required that teams generate a model; however, teams that used CAD software and a 3D model need to submit the 3D model when e-mailing the Competition Liaison the final design package.
- Teams will be disqualified if all items are not submitted by December 19, 2011.

### **Design Judging Process**

A panel of judges will assess each team's final design package in the following areas:

- Design Notebook
  - Documentation of the steps through the Design Spiral
  - Explanation of Final Design Choice
  - Explanation and reasoning of design changes
  - Documented results of the calculations for the specified loading condition(i.e. hull form, payload, etc.)
  - Creativity & Format
- Drawings
  - Format & Clarity
  - Lofting Accuracy
  - Ease of Construction
- Calculations
  - Completeness
  - Accuracy
- Design Parameters
  - Ability to install and secure the steering system, payloads, and propulsion equipment
  - Ease of construction
  - Meets minimum freeboard requirement for each loading condition

Detailed information about the judging criteria can be found in **Appendix E**. *Make sure the judging criteria are fully understood.* Contact the Design Competition Liaison if you have any questions regarding the criteria.



THE APPRENTICE SCHOOL STUDENT SECTION OF  
THE SOCIETY OF NAVAL ARCHITECTS AND MARINE ENGINEERS



**Finalist Announcement**

***Date: TBD***

All teams will be invited to a finalist announcement ceremony where the four winning designs will be announced. This is a chance for the students to network with professional shipbuilders. Location and directions will be provided at:

[www.sname.org/sname/designcompetition](http://www.sname.org/sname/designcompetition).



### **PHASE III. CONSTRUCTION, TESTING, AND COMPETITION**

#### **Construction**

The four finalists' designs will be built at Newport News Shipbuilding by Apprentice School students and skilled trade workers. If the construction team has any issues or questions during the building of the finalist's boat, they will contact the Competition Liaison as outlined in the Communication Plan.

Prior to the competition day, the Design Teams will be given the opportunity to inspect the constructed boat, complete the paint scheme (decals, etc), and perform pre-competition trials of the boat's performance. The inspection and practice sessions will be arranged with the final teams following the awards announcement.

#### **Boat Trials and Competition**

***Date: April 28, 2012***

***Rain Date: April 29, 2012***

The four finalists will be invited to validate their designs and compete for best boat performance. Each team will be given the opportunity to participate in validating their design predictions and to operate their boat remotely through designated courses. Boats will be judged based on the following factors:

- Calculation Accuracy (compared to actual tested values)
  - Draft & Trim
  - Stability
  - Weight
  - Centers of Gravity
- Ability to Accommodate Required Payload
- Speed & Maneuverability

Detailed information about the judging criteria can be found in **Appendix F**.

#### **Awards Ceremony**

***Date: April 28, 2012***

***Rain Date: April 29, 2012***

The team with the highest point total will be the winner. All teams are invited to witness the boat trials and competition and be recognized in the awards ceremony to follow. The finalist teams will be allowed to keep their boats after the competition. However, safe transportation as determined by the competition officials must be provided by the team to remove the boat from the competition site.



## APPENDIX A: COMMUNICATION

### **Purpose**

This appendix provides the guidelines for communication between Design Teams and the Competition Liaison.

Teams are encouraged to ask questions throughout the design competition. These questions should be sent directly to the Competition Liaison. Submitted questions and answers will be posted online for viewing by all teams.

After the initial question and answer orientation during the week of November 7, 2011 (date TBD), all communication shall take place via email.

### **Responsibilities**

- Design Teams
  - Appoint a peer Team Captain
  - Questions should be submitted to the Competition Liaison by the Team Captain using the website [www.sname.org/sname/designcompetition](http://www.sname.org/sname/designcompetition)
  - For finalists, the Team Captain will need to respond to the Competition Liaison in a timely manner in the event of any construction-related questions
- SNAME Student Section Competition Liaison
  - The Liaison will collect the questions and distribute to subject matter experts for resolution.
  - The Liaison will collect the answers and post them online as soon as possible
  - The Liaison will inform the Team Captain if significant time is required to provide an answer.

Please include the following information when you submit a question

- Team Name
- Advisor
- School
- Team Captain
- Phone number and/or Email address



## APPENDIX B: LIST OF MATERIALS

### Construction Material

These materials will be used to construct the finalists' designs

- (2) 10' x 5' x 1/8" thick steel plate
- All necessary weld metal for joining steel parts
- (2) paint colors and (3) paint zones
- 18" x 30" x 3/4" plywood to construct the rudder

### Payload

Each boat must carry five (5) concrete masonry units (CMU) in the arrangement prescribed in Figure 1.

To ensure that the boat meets the freeboard requirement, it is required that the hydrostatic calculations be performed for the payload configuration.

The dimensions of a standard CMU are 15-1/2"(L) x 7-5/8"(W) x 7-5/8"(H) and weighs approximately 31 pounds. The CGs should be calculated from the geometric center of each CMU.

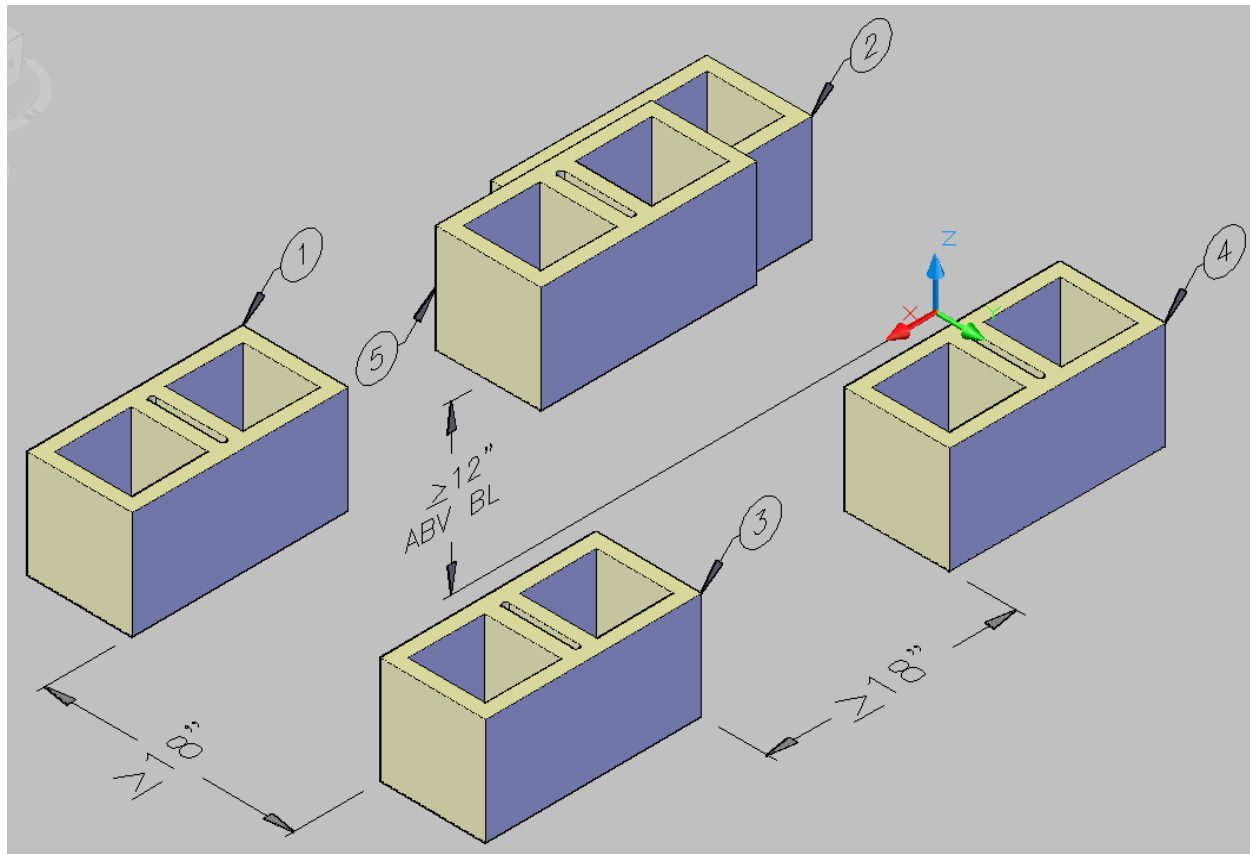

Figure 1



THE APPRENTICE SCHOOL STUDENT SECTION OF  
THE SOCIETY OF NAVAL ARCHITECTS AND MARINE ENGINEERS



The requirements for the spacing and placement of each CMU are as follows:

CMUs 1 – 4: Vertical height requirement – none

Horizontal spacing requirement – must be at least 18” between CMUs

CMU 5: Vertical height requirement – must be at least 12” from baseline to CMU bottom

Horizontal requirement – cannot be placed directly on top any other CMU(s)



## **Propulsion**

- (1) Bass Pro Shops® Prowler™ T55/40 Trolling Motor
  - Description: The trolling motor is comprised of an electronic throttle located in the upper-body, a transom mount, and a propeller capable of providing 55 lbs. of thrust.
  - Special Requirements: The Trolling Motor must be able to be quickly attached and detached without interference from the hull form or disassembly of the components. Propellers will be in a fixed orientation on the boat and not allowed to be angled or turned relative to their fixed location.
  - A 5" W x 3" H mounting plate must be included in the design. **NOTE**: The mounting plate allows for easy connect/disconnect of the motor to the boat. Include plate in all drawings.
  - Dimensions: See illustration within
  - Weight: 17.8 lbs
  - Center of gravity: The midpoint of the 40 in. shaft (estimated)
- (1) 12 Volt Deep Cycle Marine Battery
  - Description: The 12 Volt Deep Cycle Marine Battery.
  - Dimensions: 13" L x 7-1/4" W x 9-1/2" H
  - Weight: 51 lbs.
  - Center of gravity: The geometric center of the battery.
- (2) Power Cables
  - Description: Used to provide power from the battery to the steering assembly and propulsion motor.
  - Dimensions: 8 feet long
  - Weight: Negligible
  - Center of Gravity: Negligible



Propulsion motor:

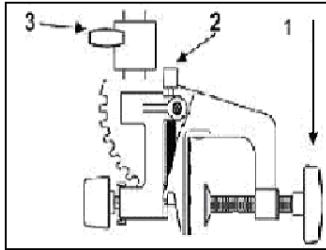

**TWIST TILLER 03 MOUNT MODEL**

- 1) **Clamp screws** - The clamp screws allow for easy motor installation and removal. Mount your motor on the transom, and then tighten the clamp screws securely.
- 2) **Tilt position pin** - This pin allows you to adjust the tilt of the motor.
- 3) **Depth collar adjustment** - The depth of the motor can be adjusted up and down by loosening the depth collar knob. The depth collar is located on the column directly above the mount. After adjusting to the position and depth desired, retighten the knob.

**NOTES:**

- (1) Not drawn to scale
- (2) All measurements are in inches
- (3) Tiller will be removed to accommodate radio control equipment
- (4) All radio control equipment shall be housed in the upper body
- (5) Mount can be positioned anywhere along the main shaft
- (6) Mounting surface template is described in the guidelines

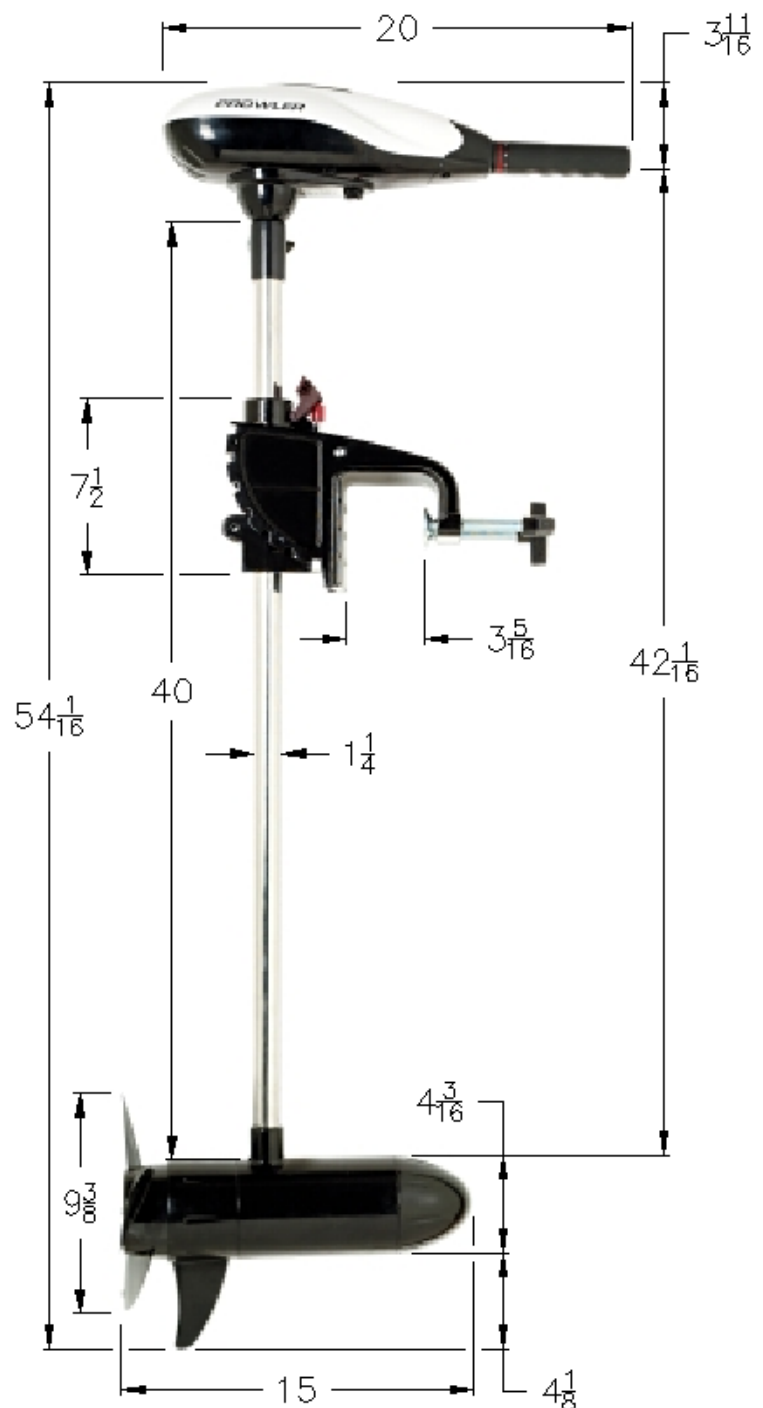



## Steering

- Steering Assembly -
  - Description: Unit containing its own power supply, receiver, linear actuator, rudder post, and rudder.
  - Special Requirements: Steering Assembly must be able to be quickly attached and detached. The attachment method should be in accordance with the template provided. **\*\*ALL THREE MOUNTING HOLES FROM THE PROVIDED TEMPLATE MUST BE USED \*\***
  - Dimensions: 24-1/4" L x 12-1/4" W x 8" H
  - Weight: 45.2 lbs.
  - Center of gravity (without rudder):
    - VCG - 2.625" from bottom of box
    - LCG - 11.625" from the front of box
    - TCG - 6.325" from port side of box
- Rudder
  - Teams will use only one rudder on boat designs
  - The teams must provide a fully dimensioned design for the rudder in the construction drawing
  - The rudder will be built from 3/4" plywood, density = .0217 lbs/in<sup>3</sup>
  - The rudder will be painted to prevent water absorption
  - Weight/Displacement: Weight and center of gravity for the rudder shall be calculated by the design team and included in the calculations spreadsheet.



## Steering Box Template (Not to Scale\*)

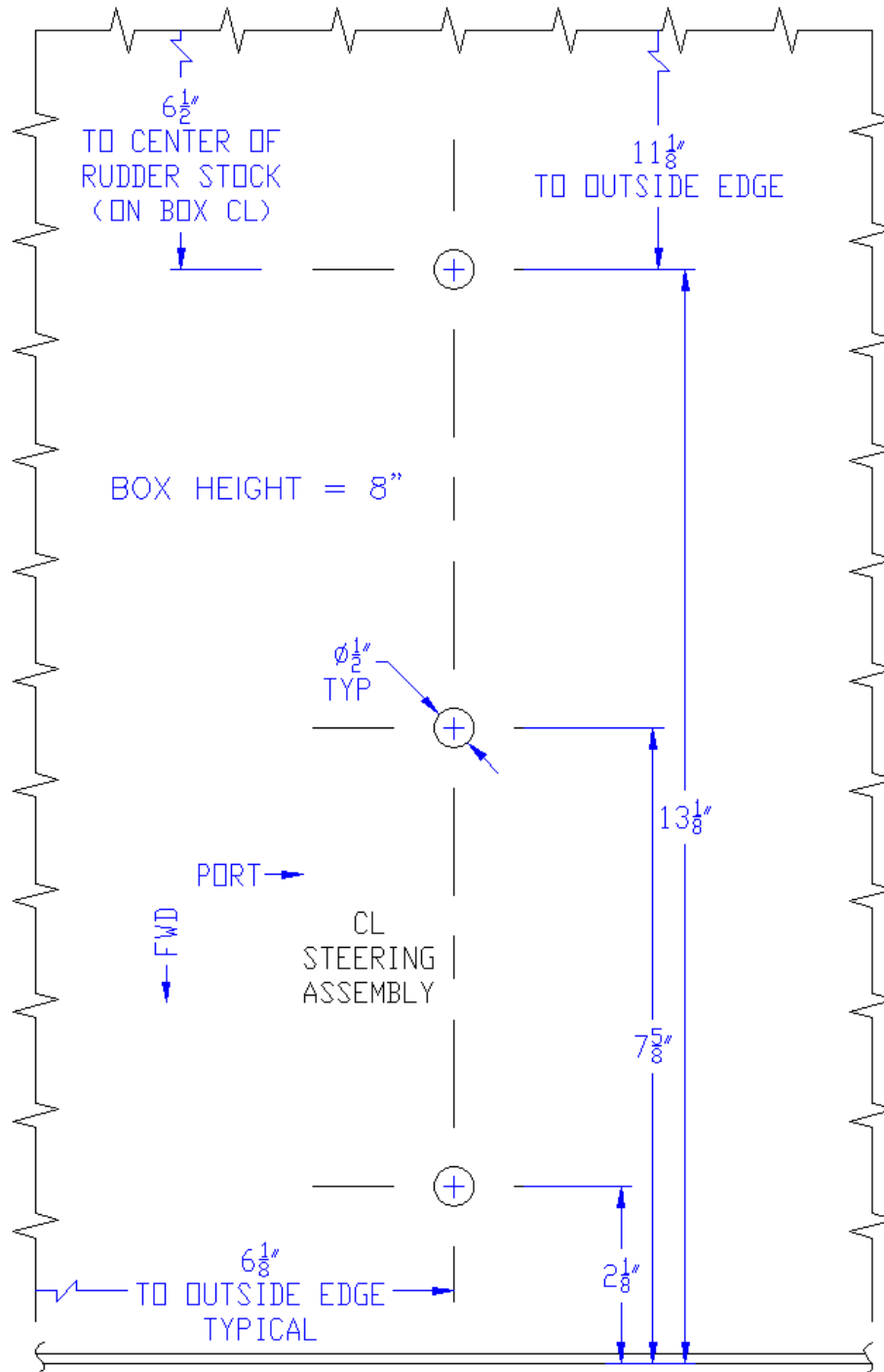

\* The overall dimensions of the steering box (12-1/4 x 24-1/4 x 8) prohibit a full scale template. The AutoCAD file is set to print an 11 x 17 sheet to give a full scale representation of the mounting requirement.



## APPENDIX C: DRAFTING GUIDELINES

The five drawings required for this project are:

1. Design Drawing: The design drawing will include the plan, elevation, section, and isometric views of the completed design with principle dimensions. The design waterline should be marked and labeled (including height above baseline at amidships, FP, and AP) on the elevation view.
2. Construction Drawing(s): The construction drawing(s) shall provide the views, details, dimensions, material list, part numbering, and notes necessary for the construction of the boat. Dimensioning each piece is required even if using CAD software and a 3D model of the design. Special attention should be paid to the location of mounting surface locations, bulkheads, hull stiffening, etc. Locations of these parts should be given from either a reference line, i.e. SHIP CL or MIDSHPIS, or from a piece of structure.
3. Nesting Plan: The nesting plan is a 2D drawing that shows the layout of each piece on the steel plates to show that all required pieces can be cut from the provided material. CAD software generated nesting plans should be full scale for easy conversion for laser cutting.
4. Paint Drawing: The paint drawing shall identify, in plan, elevation, and section views, the selected colors, zones, and decal scheme. The boats will be limited to a maximum of two colors and three zones to allow painting to be completed between construction and testing.
5. Loading Diagram: The loading diagram will show plan and elevation views with the location of each payload, the steering assembly, and propulsion equipment. (**See Appendix B**).

Drawings should include geometry, scale ratio, tolerances, and dimensions in English units. Visit [http://en.wikipedia.org/wiki/Engineering\\_drawing](http://en.wikipedia.org/wiki/Engineering_drawing) for an overview of typical engineering drawing format.

Sample drawing/layout files are available through the Support Files Link on the Competition Website ([www.sname.org/designcompetition/designtools/](http://www.sname.org/designcompetition/designtools/)).



## Dimensioning & Proper Details

Drawings should contain dimensions that aid in the understanding of the intended design. Overall dimensions, distances between parts, and proper annotation of parts are critical in conveying the design intent. Ensuring all parts have been detailed allows for easier fabrication. A good way to test this is to attempt to construct a scaled model from paper based solely on the design drawings. Concerns about the clarity of the drawing will be evident from questions during the scaled construction. **NOTE:** Dimension your drawings using 1/16<sup>th</sup> inch dimensions. Precision higher than 1/16<sup>th</sup> of an inch will reduce the clarity of your design.

## Design & Lofting

Parts intended to have curvature or bends need special attention. Simple curvature is described as bending a flat plate into a cylinder or some arc tangent of a cylinder. Complex curvature is described as bending a flat plate in two planes or a saddle shape. **Complex curvature is not allowed.** Any design containing complex curvature will be disqualified for violating the design parameters.

Curvature is not a requirement! Multiple different types of hull form designs can be accomplished without using curved plate, which has many benefits to you as designers and Naval Architects. The greatest benefit of using flat plates is the ease of locating the CGs. One note of caution, using multiple flat plates to accomplish a geometric form that require multiple plates to be welded together greatly increases the difficulty in lofting and construction. Also, plates can be bent to accomplish a similar hull form outcome and are relatively easy to calculate the CGs for. Remember, the more complicated your design, the more difficult the calculations, construction and other aspects of shipbuilding become. The winning design of 2010 was mainly comprised of flat plate with a rolled transition between the keel and the shell plating. Try different combinations and find the plate geometry that best suits your team's strengths.

Curvature can be accomplished by rolling the plate to a dimensioned radius and angle. Rolling the plate produces fair, or smooth, shapes that effectively transition the hull form without the need for welding to join separate shell plates. However, you will need to calculate and adjust the total length of plate needed to accomplish the plate forming, or rolling, to your design intent.

To calculate the total length of plate required to accomplish a roll, you must determine the plate's girth. The girth is defined as the middle of the thickness of the plate, so you will need the geometry of your plate at the middle of the thickness. This is typically accomplished by offsetting either your inner or outer geometry to the center of the plate thickness. You can then measure and find your girth dimension for the piece and create the flat plate for the nesting drawing. A simple example using a 1" thick plate is shown on the following page.



THE APPRENTICE SCHOOL STUDENT SECTION OF  
THE SOCIETY OF NAVAL ARCHITECTS AND MARINE ENGINEERS

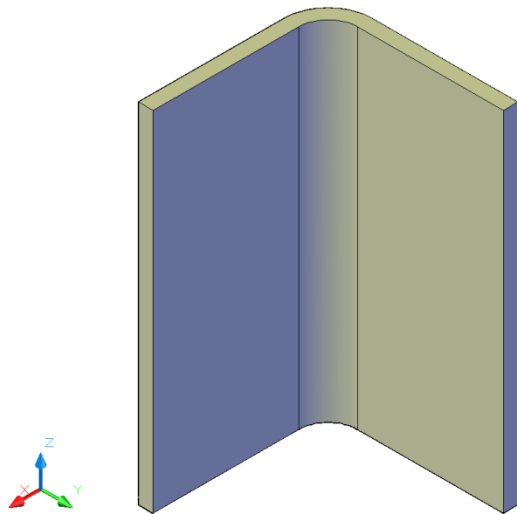

1) Plate, 1" Thick, Rolled to a 2" Radius

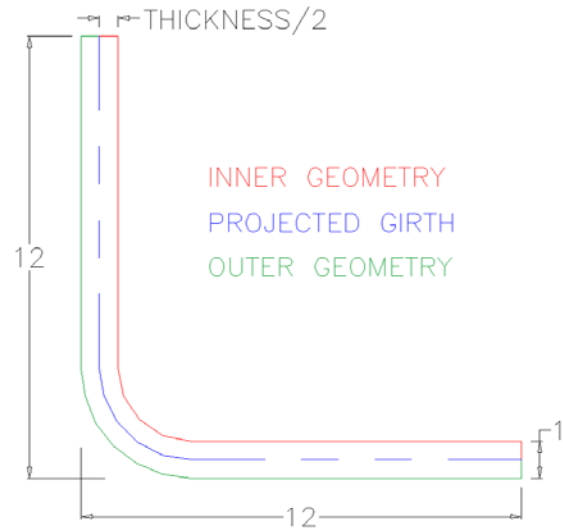

2) Plan View Showing Offset Girth

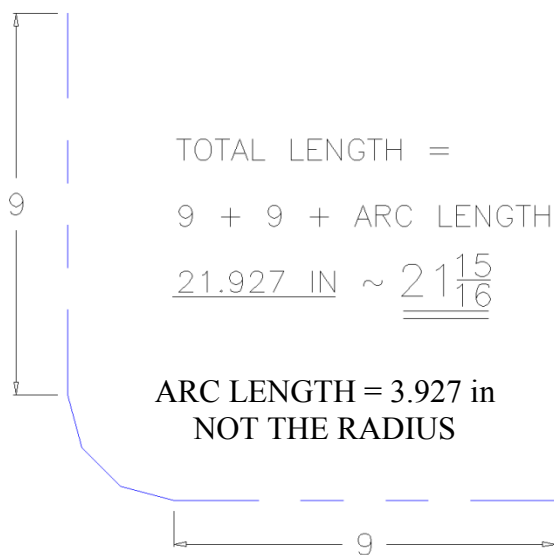

3) Total Length of Plate From Girth

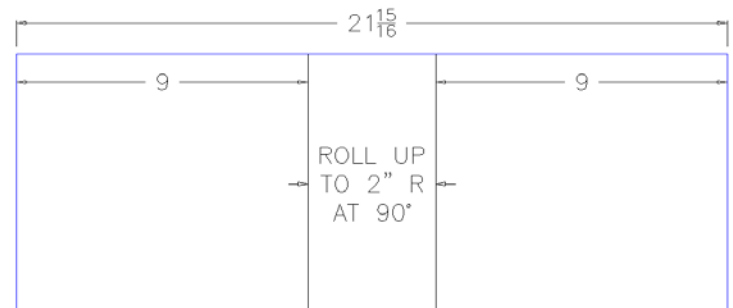

4) Lofted Part

**\*\* NOTE:** The tangency lines and roll information should be included on the part. Always "Roll Up To" the interior radius of the plate, not the middle (girth) or outer radius.



## Design & Lofting (*cont'd*)

Bent or knuckled shapes require extra dimensions to accurately fabricate. Dimensions for the rise and run of the bend angle are needed to replicate the design geometry. Bends are preferred over welding numerous pieces together, but multiple bends on a part make it increasingly difficult to fabricate. In order to meet the complex forming requirements of bent or knuckled shapes, you are limited to have only one bend or knuckle per plate. Remember that welding multiple plates together is not a preferred construction method and drawing dimensions for the exact location of parts increases each time a piece needs to be welded to another.

## Nesting Guidelines

After the individual parts that make up your design are lofted (made into 2D geometry), you're ready to generate the nesting plan. Because we use a high powered laser to cut the parts for your design, there are very few restrictions to the placement of pieces on the nesting plan. Your nesting plan should be full scale because we will use your nesting drawing to cut your designed parts. Your nesting plan should be made up of only lines, arcs, and text. Ellipses and splines cause problems with our software and equipment. Multiple overlapping lines are also problem areas, so make your nesting drawing as "clean" as possible by not having any 'line on line' issues. **Leave 1/2" border between the edge of the steel plate to any part geometry and 1/2" gap between parts.** *Failure to do so will result in point deductions.* Units for your submittals should be set to inches; our software has trouble converting any other unit setting. Also, to aid construction, the pieces should be labeled with a part number or piece callout and two directions, port, up, forward, etc. Including a List of Material on your Nesting Drawing is also encouraged to further aid construction in the fabrication and assembly of your design. A good example was submitted by the Smooth Sailing team from the Advanced Technology Center in Virginia Beach. Their Nesting Plan is included on the following page as an example.



THE APPRENTICE SCHOOL STUDENT SECTION OF  
THE SOCIETY OF NAVAL ARCHITECTS AND MARINE ENGINEERS



THE APPRENTICE SCHOOL STUDENT SECTION DESIGN COMPETITION

ITEM NO.	QTY	DESCRIPTION	MATERIAL	UNIT WEIGHT	REMARKS
1	1	BOAT	OS	602.89	USE WITH ITEM 1
2	1	PORT SIDE PIVOTON	OS	6679	USE WITH ITEM 1
3	1	STARBOARD SIDE PIVOTON	OS	6679	USE WITH ITEM 1
4	1	CENTER PIVOTON TOP	OS	21.28	USE WITH ITEM 1
5	1	CENTER PIVOTON BOTTOM	OS	24.54	USE WITH ITEM 1
6	1	CENTER PIVOTON STARBOARD SIDE	OS	18.70	USE WITH ITEM 1
7	1	CENTER PIVOTON PORT SIDE	OS	18.70	USE WITH ITEM 1
8	1	DECK PLATE	OS	21.26	USE WITH ITEM 1
9	1	CENTER PIVOTON STERN	OS	7.66	USE WITH ITEM 1
10	1	PORT BOW BRACE	OS	1.02	USE WITH ITEM 1
11	1	STARBOARD BOW BRACE	OS	1.02	USE WITH ITEM 1
12	1	STARBOARD STERN BRACE	OS	1.28	USE WITH ITEM 1
13	1	PORT STERN BRACE	OS	1.28	USE WITH ITEM 1
14	1	PORT SIDE FLAT BRACING	OS	1.70	USE WITH ITEM 1
15	1	PORT SIDE FLAT BRACING	OS	1.70	USE WITH ITEM 1
16	1	PORT SIDE BRACING	OS	4.53	USE WITH ITEM 1
17	1	STARBOARD SIDE BRACING	OS	4.53	USE WITH ITEM 1
18	1	CENTRAL BRACKET	OS	8.83	USE WITH ITEM 1
19	1	MOTOR BRACKET	OS	2.08	USE WITH ITEM 1
20	1	PORT SIDE MOTOR HOLE WALL	OS	3.83	USE WITH ITEM 1
21	1	STARBOARD SIDE MOTOR HOLE WALL	OS	3.83	USE WITH ITEM 1
22	1	FORWARD MOTOR HOLE WALL	OS	5.10	USE WITH ITEM 1
23	1	AFT MOTOR HOLE WALL	OS	5.10	USE WITH ITEM 1
24	1	STEERING ASSEMBLY	OS	40.00	USE WITH ITEM 1
25	2 BAGS	SAND	-	100.00	USE WITH ITEM 1
26	1	MOTOR	-	17.90	USE WITH ITEM 1
27	1	BATTERY	-	53.50	USE WITH ITEM 1
28	1	BUDGER	PLYWOOD	1.97	USE WITH ITEM 1

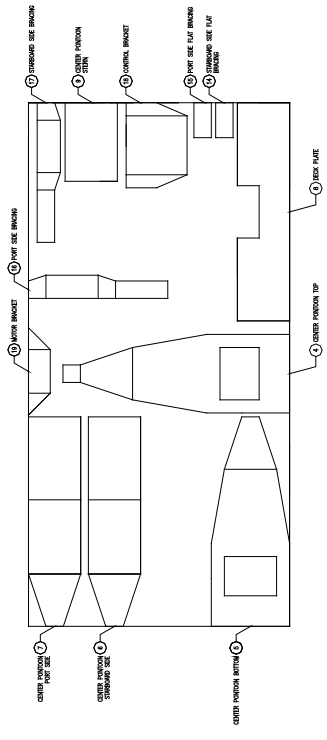
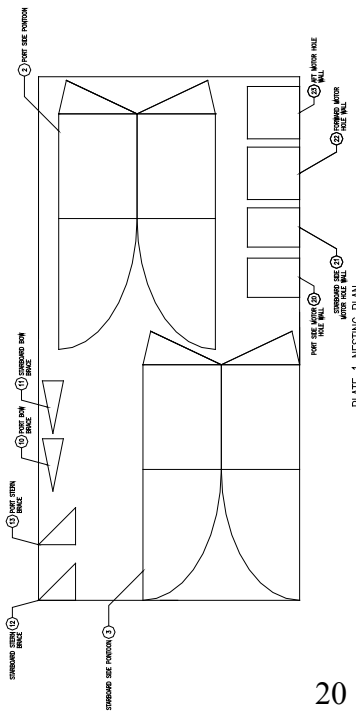

ADVANCED TECHNOLOGY CENTER  
NESTING PLAN DRAWING

DESIGNER: [Name]  
DATE: 11/11/11

SHEET 6 OF 8



## APPENDIX D: DESIGN PROCESS AND CALCULATION APPROACH

### Purpose

This appendix is intended to help each team understand the boat design process and to provide the recommended approach and calculations required to develop a good design. Visit the Glossary section of these guidelines for definitions of many of the words used in ship design and construction.

### Design Spiral

Ship design is typically an iterative process in which various aspects of the design pertaining to hull form, hydrostatics, weights, power, stability, structures, and arrangements are balanced in a certain order to arrive at an optimal design. Most of these broad requirements cannot be analyzed and/or determined independently of the other criteria on the design spiral. The design spiral generally takes the following form:

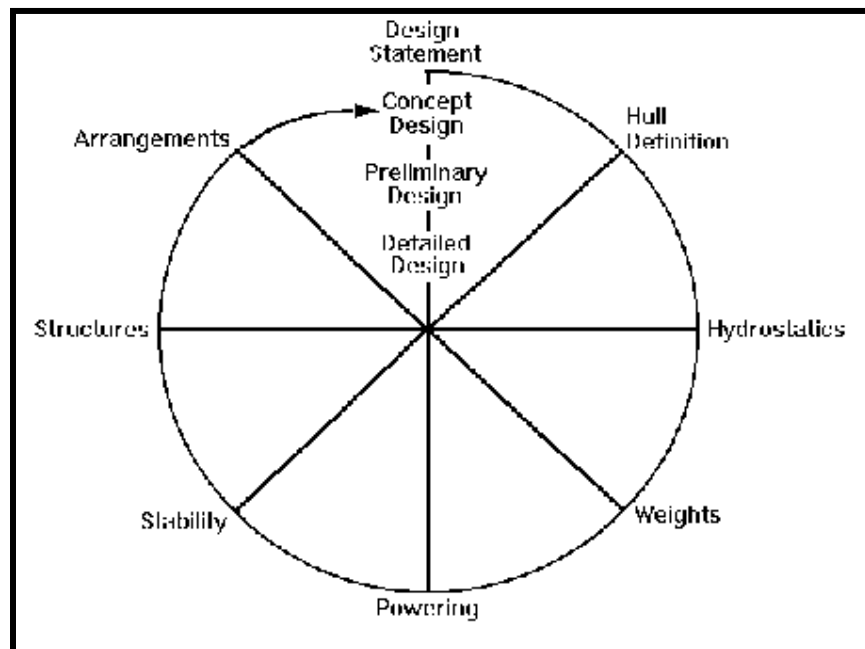

This general process can apply to a Navy ship, a commercial ship like a tanker or containership, or something as simple as a row boat. The process starts very broad and progressively gets more detailed as you progress from the concept design phase, to preliminary design, and finally to detailed design. While your design will not necessarily address each of the parameters shown on the spiral above, it can provide a useful approach to designing your vessel.

The process starts with defining the mission of the vessel in a one or two sentence design statement based on the prospective owner's requirements. Without a concise design statement, it will be difficult to create a successful design. A simple design statement also helps to keep focus on the overall purpose of the vessel.



THE APPRENTICE SCHOOL STUDENT SECTION OF  
THE SOCIETY OF NAVAL ARCHITECTS AND MARINE ENGINEERS



**Hull Definition:** Determine the general shape of the hull and its principle dimensions. Principle dimensions are the length, beam, and depth of the hull. Later steps involve the creation of a lines drawing for the ship which describes the hull form in detail. Included in this step is optimization of the rudder to produce the smallest possible turning diameter. This involves trade-offs with block coefficient and ship length. Careful examination of the calculations and design curves prior to starting your concept design may help you make some good early choices that can save you a lot of time.

**Speed:** Speed calculations require effort, modeling, and calculations beyond the scope of this competition. Calculations are not required to predict the actual speed of the boat for this competition.

**Maneuverability:** Maneuvering calculations require effort, modeling, and calculations beyond the scope of this competition so calculations are not required. However, methods to size the rudder and roughly estimate the turning performance are provided to help with the design.

**Hydrostatics:** Consider the properties of the hull as it sits at rest in the water. This includes the volume, displacement, design waterline, center of buoyancy, and metacentric height of the hull.

**Weights:** Estimate the weight of all shipboard structure and components and their location and determine the vessel's weight, its vertical, longitudinal, and transverse centers of gravity.

**Powering:** Determine what type of propulsion system will be required for the vessel to perform its mission in the most economical fashion. Major considerations include speed, fuel availability, fuel rate, space, and weight.

**Stability:** Calculate the boat's tendency to right itself when its position in the water is disturbed by an outside force like wind or waves. Stability is critical to the safety and comfort of the vessel's passengers.

**Structure:** Design the structure needed to maintain structural integrity through all sea and weather conditions that the vessel can expect to see during its lifetime. Considerations include type of material, thickness of the material, the location and size of all frames, and how the materials are joined to one another.

**Arrangements:** Determine how much space each function of the vessel requires and where that space should be located for the most efficient operation of the vessel. The final step in determining the vessel's arrangement is to develop a detailed plan of the vessel depicting every space on the vessel, its purpose, and dimensions from the highest deck to the lowest, as well as how equipment will be located in each space or compartment.



Cost: Although not shown on the generic design spiral provided here, it is important to consider the cost of the vessel as the final parameter considered during each pass through the design spiral. Cost estimation consists of an educated guess as to what materials and labor will be required for the construction of the vessel, and what each will cost.

From this point forward, the designer continues to follow the steps of the spiral, re-examining each parameter in more detail than on the previous pass. A good description of the overall design process for a boat can be found in “The Design Spiral for Computer-Aided Design” by Stephen Hollister at [www.newavesys.com/spiral.htm](http://www.newavesys.com/spiral.htm).

### **Developing a Concept Model**

To begin the design process, it is recommended that each team generate a 3D sketch and scale model of their boat. Materials will include cardstock, graph paper, ruler or scale, straight edge, utility knife, and painter’s tape.

1. Sketch a 3D concept model of your design.
2. Create a 2D scaled sketch of each of the shell pieces required to construct the boat and transfer each shell piece sketch onto cardstock (notecards, cardboard, etc).
3. Cut out the shell pieces starting with any transverse structure. Any pieces with curvature should be oversized initially, as these pieces will be trimmed at final assembly.
4. Assemble the model by taping the individual shell pieces together along seams. Assemble pieces without curvature first. Mark the pieces needing trimming, trim and reattach.

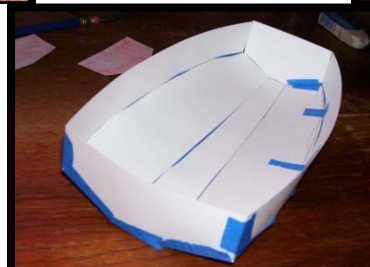
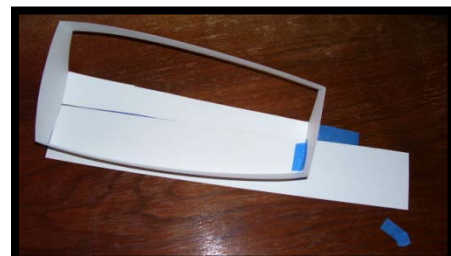
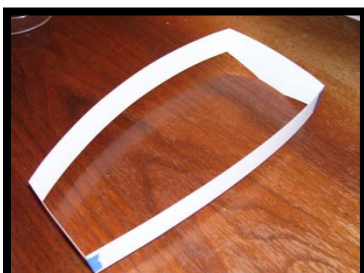



### Weight Calculation

Do the following steps for each piece of your boat:

- Calculate its weight
- Calculate its center of gravity in the longitudinal, transverse, and vertical directions from the reference point you have defined

**NOTE:** A good place for the reference point is the origin, which is the forward perpendicular, on centerline, and the baseline. Also remember that items on one side of the boat will be positive, and those on the other side will be negative. The weight calculations should include weight for all steel pieces, the motor, the steering system, the battery, the rudder, and the payload. The spreadsheets provided on the website will assist you in calculating the total weight and the boat's overall center of gravity (CG).

*Example:* This barge has a length of 6', a breadth of 2', and a depth of 1.5'. Steel plate (1/8" thick) weighs 5.1# per square foot. Sign convention is as follows: aft is positive, port is positive, and up is positive.

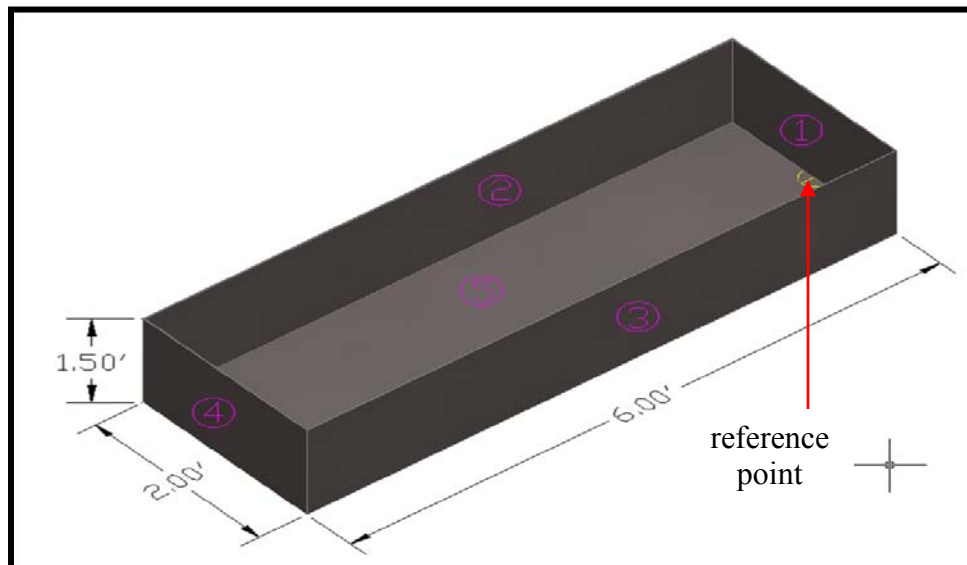

Isometric View of Barge Shape with Plating Numbered

Item	Dimensions	Area	Weight	LCG	LMOM	VCG	VMOM	TCG	TMOM
	(ft)	(ft <sup>2</sup> )	(lb)	(ft)	(ft-lb)	(ft)	(ft-lb)	(ft)	(ft-lb)
Bow plate (1)	2 x 1.5	3.0	15.3	0.00	0.0	0.75	11.5	0.00	0.0
Port plate (2)	6 x 1.5	9.0	45.9	3.00	137.7	0.75	34.4	1.00	45.9
Starboard plate (3)	6 x 1.5	9.0	45.9	3.00	137.7	0.75	34.4	-1.00	-45.9
Stern plate (4)	2 x 1.5	3.0	15.3	6.00	91.8	0.75	11.5	0.00	0.0
Bottom plate (5)	6 x 2	12.0	61.2	3.00	183.6	0.00	0.0	0.00	0.0
Total			183.6	3.00	550.8	0.50	91.8	0.00	0.0



For this very simple example, the composite longitudinal center of gravity (LCG) is 3.00 feet aft of the bow, the vertical center of gravity (VCG) is 0.50 feet above baseline, and the transverse center of gravity (TCG) is 0.00 feet off centerline.

### **Hydrostatics**

The boat's displaced volume and centers at the design waterline are calculated using the offsets (the distance from the boat's centerline to the hull) at a series of waterline and station intersections. The boat's underwater shape is calculated by plotting these offsets along the boat's length. The offsets are used to calculate the station and waterline areas. The resulting areas can then be integrated using Simpson's Rule to calculate volumes and centers.

$$\text{Simpson's Rule} = \frac{h}{3} (A_0 + 4(A_1) + 2(A_2) + \dots + 4(A_{n-1}) + A_n)$$

Where:

n = number of intervals (must be an even number of equally spaced intervals, resulting in an odd number of sections)

h = interval length (either section spacing or waterline increments)

A = area below design waterline (section or waterplane)

This equation will be represented throughout the remaining calculations as follows:

$$\text{Simpson's Rule} = \frac{h}{3} \sum A(SM)$$

Where SM (Simpson's Multiplier) is the coefficient (1,4,2,4,2...4,1) which is multiplied by the area.

The spreadsheet provided (on the website) allows you to input your offsets at each station and waterline, and returns the station and waterline areas, as well as the volumes and centers. All of the equations used in this process are contained within these guidelines so that you can get a better understanding of who these calculations are being accomplished – if you make an effort to understand these equations it will help you a great deal in producing the best possible design.

These offsets can be determined either by using a computer generated model of the boat, or by building a cardstock model.



### Determining Offsets Using Cardstock Model

1. Longitudinally divide the previously constructed cardstock model into eight equally spaced sections, marking the divisions with pencil lines. This should result in a total of nine “stations” – the front (bow) of the boat, seven equally spaced lines, and the back (stern) of the boat.

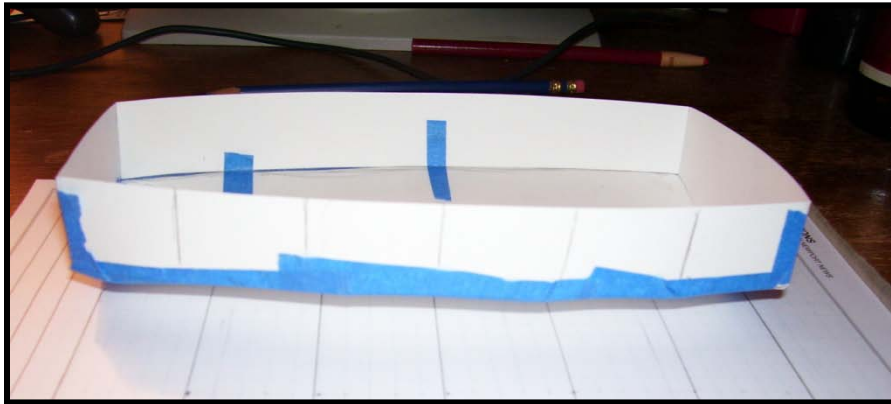

2. Cut transverse sections from graph paper to fit the marked sections. This takes a bit of patience, but can be accomplished with persistence.



3. Measure the distance from the centerline to the hull at each of seven waterlines (the highest of which should be the deck edge). These waterlines should also be equally spaced. Don't forget that the first of the seven waterlines should be at your boat's



baseline. Measure the distance from the center line of the section to the edge of the paper (where it would have intersected the hull) at each of the marked waterlines.

### **Incorporating the effect of the payload into the weights and hydrostatics**

The weight and hydrostatics process must be looked at for each of the three payloads, changing the payload used in your weights each time. In this way you can ensure that your boat works with each of the three payloads that your boat must be capable of carrying. **Your job is to zero in on a design that works equally well for all of the three possible payloads!**

1. Use payload #1 and perform the weight and hydrostatics calculations.
2. Change the payload to #2 and repeat the process. You can place the second payload wherever you need to in order for the hydrostatics to work out. This may be an iterative process. If you cannot find a place on your boat to place the payload and get the hydrostatics to work out, then you will need to change your design and start over.
3. Change the payload to #3 and repeat the process.

### **Calculating Displacement**

**Volume (below design waterline) (ft<sup>3</sup>):**

$$\nabla = \left(\frac{h}{3}\right) \left(\sum A(SM)\right)$$

Note: This equation can use either the waterplane or sectional areas (Recommended) to determine the volume at the design waterline. When employing this equation, be sure to include **each** hull for boats with more than one hull.

**Hull Displacement (lbs):**

$$\Delta = \nabla * \text{Specific Weight}$$

Where:

$$\text{Specific Weight of fresh water} = 62.4 \text{ lbs/ft}^3$$

**Total Boat Displacement (lbs):**

$$\Delta_T = \Delta + \Delta_{Rudder} + \Delta_{Motor}$$

Where:

$$\Delta_{Motor} \approx 0.05 \text{ ft}^3$$

$\Delta_{Rudder}$  is calculated from your rudder design. (Consider if your rudder is completely submerged.)



## Calculating Hydrostatic Centers

### Longitudinal Center of Buoyancy about the forward perpendicular (FP):

$$LCB = \frac{\text{Moment of } \nabla \text{ about}}{\nabla} = \frac{(\sum A_s (SM)X)}{\sum A_s (SM)}$$

Where:

$A_s$  = Sectional Areas

$X$  = Longitudinal distance between the section and your design reference point

### Vertical Center of Buoyancy:

$$VCB = \frac{(\sum A_{WP} (SM)Z)}{\sum A_s (SM)}$$

Where:

$Z$  = Vertical distance between the waterplane and baseline

$A_{WP}$  = Waterplane Area

### Center of Flotation:

$$CF = \frac{(\sum b(SM)X)}{\sum b(SM)}$$

Where:

$b$  = Breadth of boat

$X$  = Longitudinal distance between the section and FP

## Moments of Inertia

### Transverse Moment of Inertia of the Waterplane (around centerline):

**NOTE:** For those designs with more than one hull (catamaran or trimaran), the transverse inertial calculations you perform as shown below are for one of the hulls. For a catamaran, add  $I_T$  to  $Ad^2$  for each hull.

$$I_T = \left(\frac{1}{3}\right)\left(\frac{h}{3}\right)(\sum b^3(SM))$$



***For each hull of catamaran:***

$$I_{T1} = \left(\frac{1}{3}\right)\left(\frac{h}{3}\right)\left(\sum b^3(SM)\right)$$

Add a factor,  $Ad^2$  for the moment transfer to the overall centerline of the boat. Where:  $A$  is the waterplane area and  $d^2$  is the distance from each hull centerline to the overall boat's centerline.

***For each hull of a trimaran:***

$$I_{T1} = \left(\frac{1}{3}\right)\left(\frac{h}{3}\right)\left(\sum b^3(SM)\right)$$

Add the same factor,  $Ad^2$ , for each of the outboard hulls to  $I_{T1} + I_{T2} + I_{T3}$  of all three hulls.

**Longitudinal Moment of Inertia of Water Plane (around midship):**

$$I_{Midship} = \frac{(h)^3}{3}\left(\sum b(SM)X^2\right)$$

**Longitudinal Moment of Inertia of Water Plane (around center of gravity):**

$$I_L = I_{Midship} - A_{WP}(CF)^2$$

## **Stability and Trim Calculations**

**Longitudinal Metacentric Radius:**

$$BM_L = \frac{I_L}{\nabla}$$

**Distance from Baseline to the Longitudinal Metacenter:**

$$KM_L = VCB + BM_L$$

**Longitudinal Metacentric Height:**

$$GM_L = KM_L - VCG$$



**Transverse Metacentric Radius:**

$$BM_t = \frac{I_t}{\nabla}$$

**Distance from Baseline to the Transverse Metacenter:**

$$KM_t = VCB + BM_t$$

**Transverse Metacentric Height:**

$$GM_t = KM_t - VCG$$

**Moment to Trim 1 Inch:**

$$MT1 = \frac{\Delta(GM_L)}{12(\text{Length of Boat})}$$

**Trim:**

$$TRIM = \frac{\Delta(LCB - LCG)}{12 * MT1}$$

**Speed**

Listed are some good ideas that should be followed to maximize your boat speed.

- 1) Design for a length to beam ratio of between 6 and 8. Within this range, the higher ratio should lead to a faster boat.
- 2) Smaller Block Coefficients (“finer” shapes) typically go faster.
- 3) Minimizing the wetted surface (the surface area of the boat below the waterline) reduces friction and generally results in increased speed.
- 4) Minimize abrupt transitions and shapes. Streamline your hull as much as you can.



## Maneuverability

First, estimate the rudder size using the *Det Norske Veritas* formula below:

$$A = \frac{T \times LBP}{100} \left[ 1 + 25 \left( \frac{B}{LBP} \right)^2 \right]$$

Det Norske Veritas

Where:

A = Area of rudder

T = (Draft) is the distance from the waterline to the lowest point in the ship

LBP = the distance between the aft perpendicular and the forward perpendicular

B = Beam (B) the width of the hull

This equation was originally intended for much larger ships, so to make it applicable to boats the size of the one you are designing, you need to multiply the answer that you got from the equation above by another factor (the square root of the length of your boat) to get the final area of one side of your rudder:

$$A' = A * \sqrt{LBP}$$

The rudder stock will be located at a point on the center line one third the total length back from the leading edge, as illustrated below. The length to thickness ratio of the rudder will be 10% (NACA 0010). Use the rudder area to determine the height, root, and tip lengths shown below.

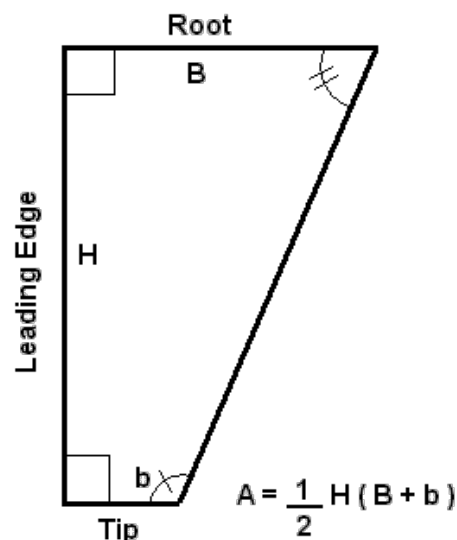



**APPENDIX E: DESIGN PHASE JUDGING CRITERIA**

JUDGING CRITERIA		Poor (0 pt)	Fair (1 pts)	Good (3 pts)	Excellent (5 pts)
DESIGN NOTEBOOK	EXPLANATION OF DESIGN	Content was lacking organization and explanation of design journey	Organization and explanation of design journey was lacking technical details	Organization and explanation of design journey was supported with technical details in a professional manner	Organization and explanation of design journey was supported with technical details, photos and charts in a professional manner
	CREATIVITY & FORMAT	Unprofessional appearance, lacking enthusiasm	Professional appearance, lacking enthusiasm	Professional appearance contains enthusiasm	Professional appearance contains enthusiasm, vibrant, high team spirit
DRAWINGS	FORMAT & CLARITY	Drawings are unclear, lacking dimensions, and improperly formatted	Drawings are lacking dimensions	Drawings contain proper dimensions and views	Drawings contain proper dimensions and views in accordance with the guidelines
	EASE OF CONSTRUCTION	Construction is not possible based on design drawing	Construction is difficult and modifications are necessary to meet requirements	Construction can be accomplished with only minor modifications to meet requirements	Construction can be accomplished with no modifications to meet requirements
CALCULATIONS	COMPLETENESS	Calculations were not provided or very little effort was put into the calculations	Some calculations were provided. Not all weights and centers were accounted for	Most calculations were provided. Loading conditions incomplete	All calculations were provided. All conditions accounted for
	ACCURACY	The weight and center calculations were inaccurate or missing	The majority of the weight and center calculations were inaccurate	Most, but not all of the weight and center calculations were accurate within 10-20 percent	All of the weight and center calculations were accurate within 0-10 percent



**APPENDIX F: TEST PHASE JUDGING CRITERIA**

	2 Points	4 Points	6 Points	8 Points	10 Points
<b>DRAFT AND TRIM</b>	The boat's actual waterline and trim were not close to the estimated waterline and trim.	The boat's actual waterline and trim were within 20-25 percent of the estimated waterline and trim.	The boat's actual waterline and trim were within 15-20 percent of the estimated waterline and trim.	The boat's actual waterline and trim were within 10-15 percent of the estimated waterline and trim.	The boat's actual waterline and trim were within 0-10 percent of the estimated waterline and trim.
<b>STABILITY</b>	The boat was not stable when placed in the water and loaded.	The boat was stable in the water, but the GM missed the calculated value by > 50%.	The boat was stable in the water, and the GM missed the calculated value by between 25% and 50%.	The boat was stable in the water, and the GM missed the calculated value by between 10% and 25%.	The boat was stable in the water, and the GM missed the calculated value by less than 10%.
<b>WEIGHTS</b>	Weight calculations were accurate within 25%	Weight calculations were accurate within 20%	Weight calculations were accurate within 15%	Weight calculations were accurate within 10%	Weight calculations were accurate within less than 5%
<b>CENTERS OF GRAVITY</b>	Center of gravity calculations were accurate within 25%	Center of gravity calculations were accurate within 20%	Center of gravity calculations were accurate within 15%	Center of gravity calculations were accurate within 10%	Center of gravity calculations were accurate within less than 5%
<b>SPEED &amp; MANEUVERABILITY</b>	1 <sup>st</sup> Stage	1 <sup>st</sup> place = 20 pts, 2 <sup>nd</sup> Place = 15 pts, 3 <sup>rd</sup> Place = 10 pts, 4 <sup>th</sup> Place = 5 pts			
	2 <sup>nd</sup> Stage	1 <sup>st</sup> place = 20 pts, 2 <sup>nd</sup> Place = 15 pts, 3 <sup>rd</sup> Place = 10 pts, 4 <sup>th</sup> Place = 5 pts			
	3 <sup>rd</sup> Stage	1 <sup>st</sup> place = 20 pts, 2 <sup>nd</sup> Place = 15 pts, 3 <sup>rd</sup> Place = 10 pts, 4 <sup>th</sup> Place = 5 pts			



## COMPETITION DAY

### **Payload Testing:**

The four finalists will be judged on their ability to secure the payload and meet freeboard requirements. Points will be deducted if deviations are made from the loading plan on race day.

### **Speed and Maneuverability:**

This event is the culmination of the boat design competition. The final four teams will compete in a series of exercises that will test their boats' speed and maneuvering capabilities. The event will consist of three stages of competition.

#### **1<sup>st</sup> Stage – High Speed Test**

- Four finalists simultaneously competing
- Determine the top speed of boat
- Points awarded according to finishing order

#### **2<sup>nd</sup> Stage – Maneuverability Test**

- Four finalists simultaneously competing
- Assesses handling and stability of boat
- Boats start from a stopped position and go to full forward throttle
- After 5 seconds, all boats will turn hard to port
- Teams will be timed on the completion of 3 high speed turns
- Points awarded according to finishing order



### 3<sup>rd</sup> Stage – Head to Head Race

- Double Elimination Bracket
- Points awarded according to race outcome
- Boats start on opposite sides and on start signal, boats travel counter-clockwise.
- Objective is to catch or pass the opponent's boat
- See course below

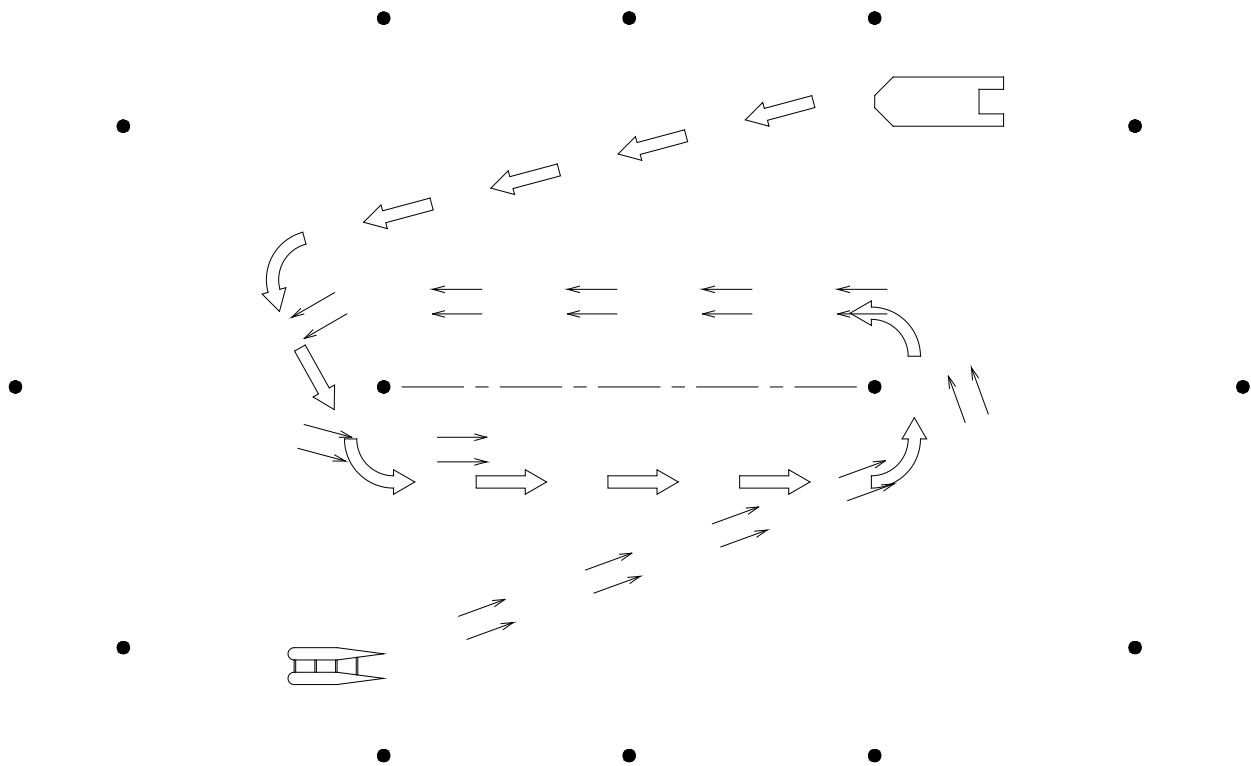



## GLOSSARY

<b>Abeam</b>	At right angles to the centerline away from a ship
<b>Aft</b>	Toward, at, or near the stern
<b>Aft Perpendicular (AP)</b>	Vertical line that passes through the intersection of the design waterline and the aftermost portion of the hull
<b>Amidships</b>	At or near the midship section (middle portion) of the ship
<b>Appendages</b>	Items or features outside the outline of the hull (e.g. rudder)
<b>Athwartships</b>	In a transverse direction; across the ship at right angles to the fore and aft centerline
<b>Awash</b>	Level with the surface of the water, so as to be covered due to wave action
<b>Baseline (BL)</b>	A horizontal line, or plane, through the lower point of a ship's hull from which all vertical measurements are taken
<b>Beam or Breadth</b>	Maximum width of the boat
<b>Block Coefficient (<math>C_B</math>)</b>	Ratio of boat's submerged volume to the volume of a block defined by length, beam, & draft
<b>Bow</b>	Forward end of boat
<b>BM</b>	Distance from Metacenter to Center of Buoyancy
<b>Bulkhead</b>	Partition that forms a compartment (a wall)
<b>Center of Buoyancy (CB)</b>	The geometric center of gravity of the immersed volume of the displacement or of the displaced water determined solely by the shape of the underwater body of the ship
<b>Center of Floatation (CF)</b>	The geometric center of the water plane at the design waterline at which the ship floats
<b>Center of Gravity (CG)</b>	The point at which the combined weight of all the individual items going to make up the total weight may be considered as concentrated; measured relative to the forward, middle, or aft perpendicular and above baseline or below a stated waterline
<b>Centerline (CL)</b>	A plane down the center of the boat, extending from bow to stern
<b>Compartment</b>	A confined space (a room in a boat)
<b>Depth (D)</b>	Vertical distance from the top of the boat at the side to the baseline
<b>Displacement (<math>\Delta</math>)</b>	Total weight of the ship when afloat including everything on board
<b>Draft (T)</b>	Vertical distance from the waterline to the baseline
<b>Elevation View</b>	A view cut longitudinally through the boat with the bow to the right showing length and depth
<b>Forward or fore</b>	Near, at, or toward the bow of the boat
<b>Forward Perpendicular (FP)</b>	Vertical line that intersects the waterline and the forward portion of the hull
<b>Freeboard</b>	The distance from top of the boat to the waterline (depth minus



THE APPRENTICE SCHOOL STUDENT SECTION OF  
THE SOCIETY OF NAVAL ARCHITECTS AND MARINE ENGINEERS



	draft)
<b>GM</b>	A vertical distance center of gravity and metacenter. A measure of stability.
<b>Length Between Perpendiculars (LBP)</b>	Distance between the FP and the AP
<b>Length Overall (LOA)</b>	Total length of the boat
<b>List</b>	A tendency to lean to port or starboard
<b>Longitudinal Center of Buoyancy (LCB)</b>	The geometric center of the submerged volume of a boat through which the buoyancy acts. Measured as the distance above the baseline.
<b>LCG</b>	Longitudinal of gravity
<b>Metacenter</b>	Fixed point in space above a boat about which it rotates
<b>Moment</b>	Force times a distance
<b>Origin</b>	Reference point location of coordinate system (Recommended location is at CL, BL, FP)
<b>Nesting</b>	Layout of parts to be cut from a sheet of material.
<b>Payload</b>	The total weight of cargo that a vessel is designed to carry
<b>Plan View</b>	A view looking down at an object showing length and breadth
<b>Port</b>	The left side of the boat when looking forward
<b>Rudder</b>	Blade shape device used to steer the boat
<b>Rudder Stock</b>	Vertical shaft that connects the rudder to the steering mechanism
<b>Section View</b>	A view cut transversely through the boat showing beam and depth
<b>Shaft</b>	A rod that connects motor and propeller
<b>Starboard</b>	The right side of the boat when looking forward
<b>Stern</b>	Aft end of the boat
<b>TCG</b>	Transverse Center of Gravity
<b>Transverse</b>	Distances port or starboard at right angles to centerline
<b>Trim</b>	A difference between the forward and aft draft
<b>Vertical Center of Buoyancy (VCB)</b>	The geometric center of the submerged volume of a boat through which the buoyancy acts.
<b>VCG</b>	Vertical Center of Gravity
<b>Waterline</b>	Line of intersection between the surface of the water and the boat's hull
<b>Waterplane</b>	The plane bounded by a waterline